

CIRCUIT ADJUSTMENT (回路調整)

STEP ステップ	ADJUST ITEM 調整	INPUT SIGNAL 入力信号 LOAD 負荷	PROCEDURE 電圧検出		ADJUST 調整箇所	REMARKS 調整・備考
			TEST EQ'PT 検出器	CONNECTING POINT 接続点		
POWER AMP ASSEMBLY (717-0014-00) Note 1. Internal input resistance of volt-ohm meter should be higher than 10 kohms. テスターは、入力抵抗10Ω以上のものをお使い下さい。 Note 2. Adjustments should be made in case of the PC Board or Transistors being changed. 調整はPCボードあるいはトランジスタを交換した場合行って下さい。 Note 3. With 30 minutes interval after putting power switch ON, repeat 1 to 4 adjustments. 通電30分後、1~4の調整を反復行って下さい。 Note 4. Adjustment is made at test point with shorting connector jack removed. After adjustment completed make sure to plug test point with shorting connector jack. 調整はテストポイントのショートコネクタジャックをはずし行って下さい。又、調整後は必ず取りつけて下さい。						
1	Normal Operation Bias Current for Lch. Lch: バイアス電流	No Input 無入力 No Load 無負荷	V.O.Meter set range to less than DC0.3V テスター DC0.3V以下のレンジ	Power Amp Assembly (717-0014-00) Between test point ⊕anb⊖ テストポイント⊕⊖間	VR 1 Power Amp Assembly (717-0014-00)	Adjust for "88mV" reading of V.O.Meter ※Operation mode set at NORMAL テスターの指示DC"88mV"に調整 ※OPERATION SWをNORMALに セット
2	Normal Operation Bias Current for Rch. Rch: バイアス電流				VR 2 Power Amp Assembly (717-0014-00)	Adjust for "300mV" reading of V.O.Meter ※Operation mode set at CLASSA テスターの指示DC"300mV"に調整 ※OPERATION SWをCLASSAに セット
3	Class-A Operation Bias Current for Lch. Lch: バイアス電流					
4	Class-A Operation Bias Current for Rch. Rch: バイアス電流					
METER CALIBRATION (Located PROTECTION CIRCUIT ASSEMBLY 720-0007-00) メータ調整 Note 1. Adjustment should be repeated until correct meter indication is obtained. 1~4の調整はメータの指ボが正しくなるまで数回繰返して下さい。 Note 2. Meter function switch is set at Normal position. メータファンクションスイッチはNORMALポジションをON						
1	Peak-0 dB Calibration for Lch. Lch: 0 dB 校正	1kHz Sine Wave 正弦波 No Load 無負荷	VTVM	Speaker Terminals	VR 3 Protection Circuit Assembly	Adjust input signal so that VTVM reads 32.25V. Then adjust VR3 and VR4 so that Meter read 0 dB. VTVMの指示32.25Vになる入力信号を 入れ、メータの指示が0 dBとなるよう にVR3,4を調整
2	Peak-0 dB Calibration for Rch. Rch: 0 dB 校正				VR 4 Protection Circuit Assembly	
3	Linearity Adjustment for Lch. 直線性調整				VR 1 Protection Circuit Assembly	Adjust input signal so that VTVM reads 1.02V (-30dB). Then adjust VR1 and VR3 so that Meter reads -30dB. VTVMの指示1.02V (-30dB)となる入 力信号にし、メータの指示が-30dBと なるようにVR1,2を調整
4	Linearity Adjustment for Rch. 直線性調整				VR 2 Protection Circuit Assembly	

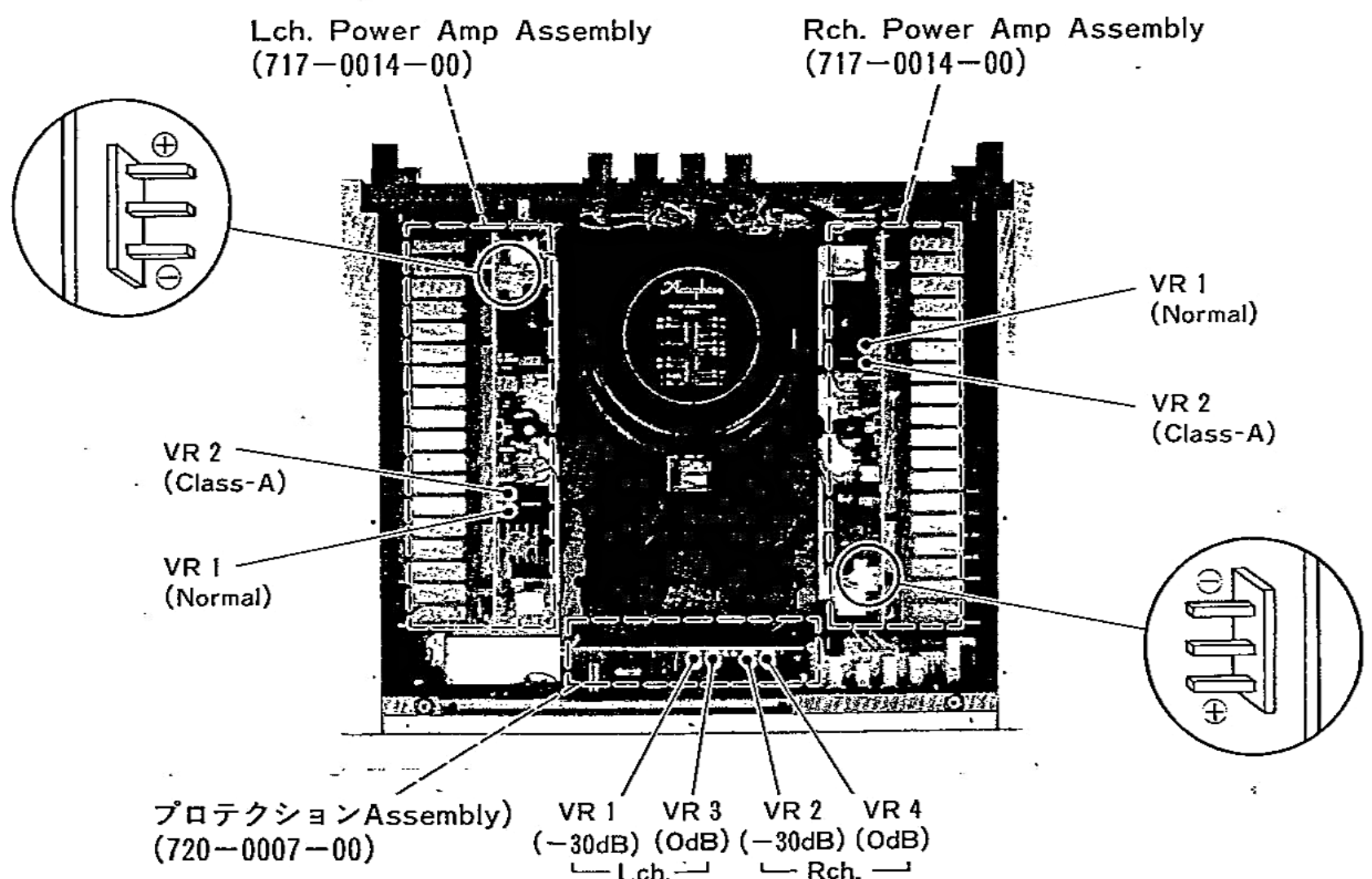

P-266 SCHEMATIC DIAGRAM

- NOTES
- The heavy lines on the schematic denote the signal path.
 - Big spots denote the ground.
 - The mark of capacitors and resistors on the schematic are:
 - METALIZED FILM CAPACITORS.
 - ⊖ POLYSTYRENE FILM CAPACITORS.
 - ⊕ METALIZED POLYESTER FILM CAPACITORS.
 - ⊙ CERAMIC CAPACITORS.
 - ⊘ MICA CAPACITORS.
 - ⊚ TANTALUM SOLID CAPACITORS.

- ⊖ METALIZED FILM CAPACITORS.
 - ⊕ POLYSTYRENE FILM CAPACITORS.
 - ⊕ METALIZED POLYESTER FILM CAPACITORS.
 - ⊙ CERAMIC CAPACITORS.
 - ⊘ MICA CAPACITORS.
 - ⊚ TANTALUM SOLID CAPACITORS.
 - ⊖ METAL FILM RESISTORS.
 - ⊕ OXIDE METAL FILM RESISTORS.
 - ⊙ METAL PLATE RESISTORS.
- Unless otherwise specified: Capacitors are ELECTROLYTIC types. Resistors are CARBON FILM type. 1/4 watt and ±5% tolerance.

- ⊖ METAL FILM RESISTORS.
 - ⊕ OXIDE METAL FILM RESISTORS.
 - ⊙ METAL PLATE RESISTORS.
- Unless otherwise specified: Capacitors are ELECTROLYTIC types. Resistors are CARBON FILM type. 1/4 watt and ±5% tolerance.

4. VOLTAGE : Operating with no input. Indicates respective voltage loading. When an input of 1KHz 1.31V is fed to "INPUT" Each value with the mark of (N) and (A) show voltage and current on each operations of NORMAL(N) and CLASS-A(A).
5. CURRENT : Operating with no input.

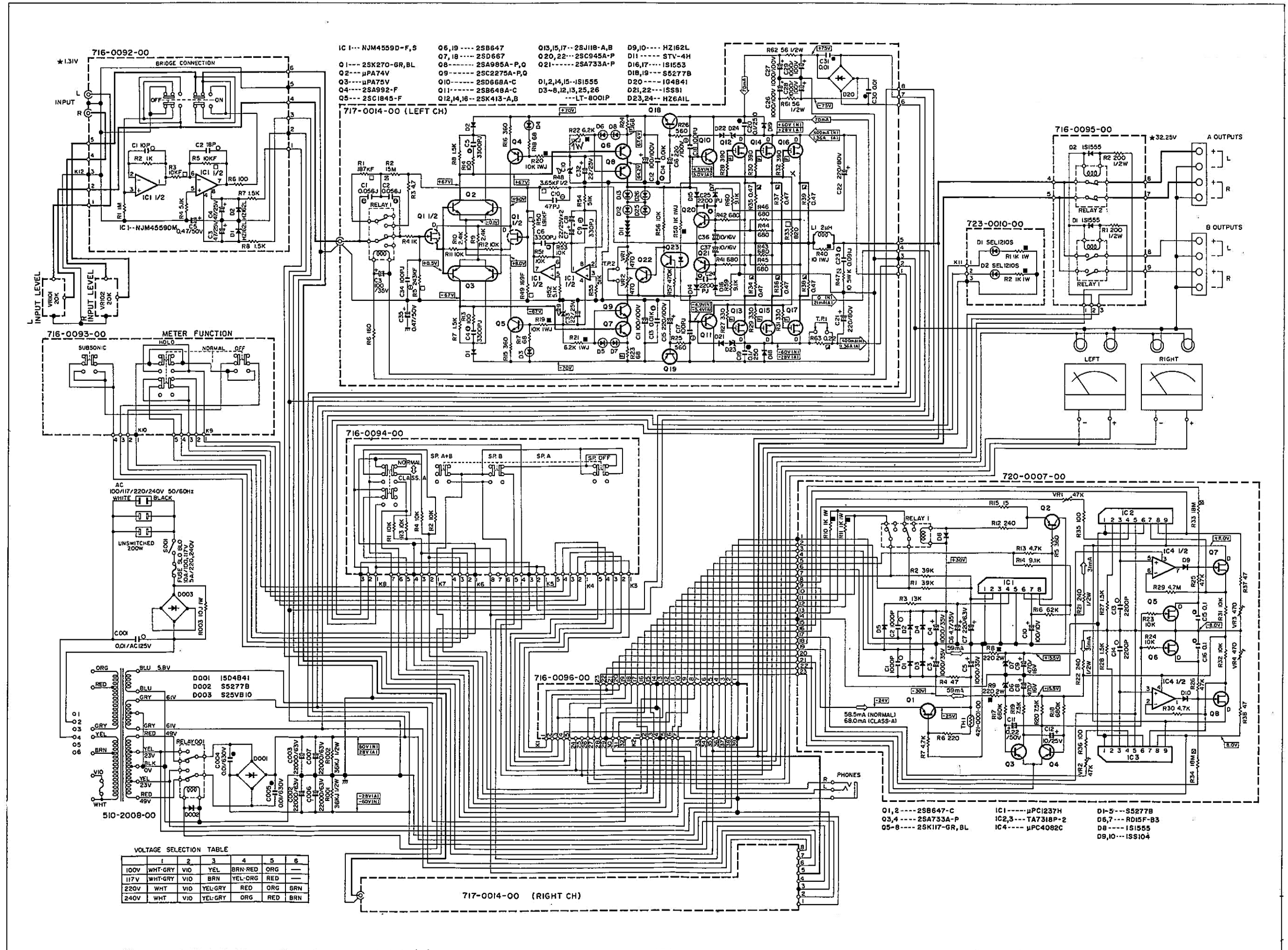

- IC 1--- NJM4559D-F, S
- Q1,19 --- 2SK270-GR,BL
- Q2 --- μ PA74V
- Q3 --- μ PA75V
- Q4 --- 2SA992-F
- Q5 --- 2SC1845-F
- Q6,19 --- 2SB647
- Q7,18 --- 2SD667
- Q8 --- 2SA985A-P,Q
- Q9 --- 2SC2275A-P,Q
- Q10 --- 2SD668A-C
- Q11 --- 2SB648A-C
- Q12,14,16 --- 2SK413-A,B
- Q13,15,17 --- 2SJ118-A,B
- Q20,22 --- 2SC945A-P
- Q21 --- 2SA733A-P
- Q1,2,14,15 --- 1S1555
- D3-8,12,13,25,26
- LT-8001P
- D23,24 --- HZ6A1L
- D11 --- STV-4H
- D16,17 --- 1S1553
- D18,19 --- S5277B
- D20 --- 1G4841
- D21,22 --- 1SS81
- D23,24 --- HZ6A1L

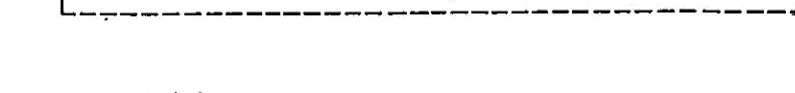
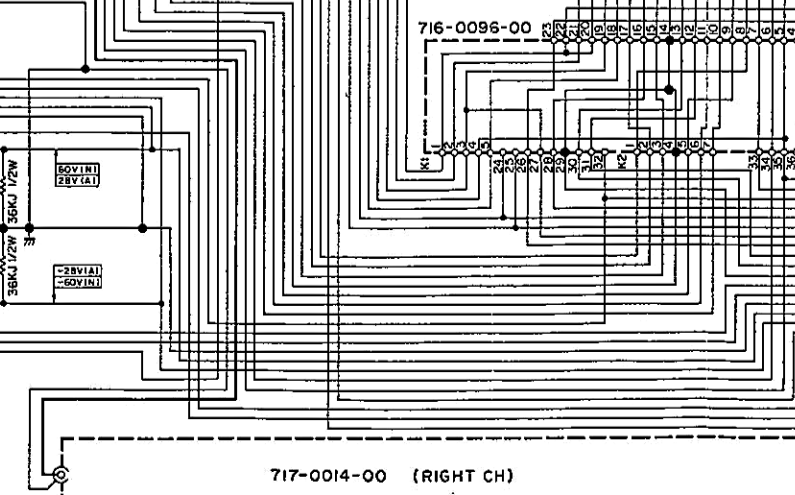
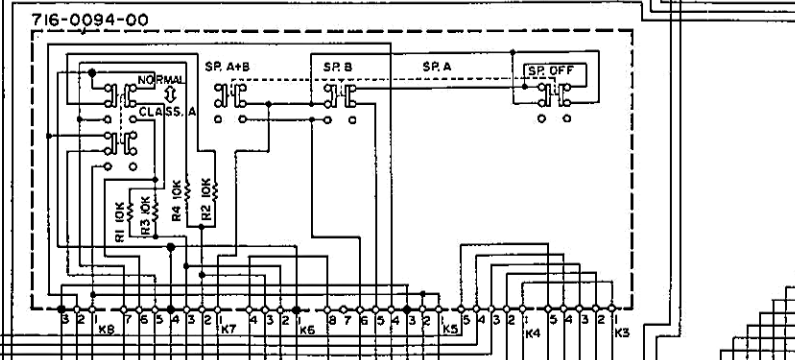
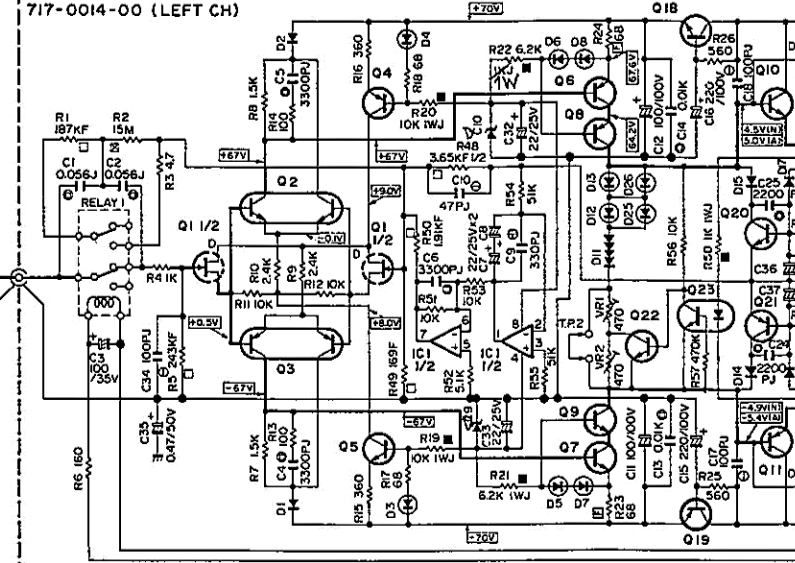

- O1,2 --- 2SB647-C
- O3,4 --- 2SA733A-P
- O5-8 --- 2SK117-GR,BL
- IC1 --- μ PC1237H
- IC2,3 --- TA7318P-2
- IC4 --- μ PC4082C
- D1-5 --- S5277B
- D6,7 --- RD15F-B3
- D8 --- 1S1555
- D9,10 --- 1SS104

VOLTAGE SELECTION TABLE

	1	2	3	4	5	6
100V	WHT-GRY	VIO	YEL	BRN-RED	ORG	---
117V	WHT-GRY	VIO	BRN	YEL-ORG	RED	---
220V	WHT	VIO	YEL-GRY	RED	ORG	BRN
240V	WHT	VIO	YEL-GRY	ORG	RED	BRN